

E20 Series

Diameter ø20mm Shaft type/Hollow shaft built-in type Incremental Rotary Encoder

■ Features

- Diameter ø20mm of miniature rotary encoder
- Easy installation at narrow space
- Small moment of inertia
- Power supply : 5VDC, 12VDC ±5%
- Various output types

⚠ Please read "Caution for your safety" in operation manual before using.



E20S Series



E20HB Series

■ Ordering information

E20	S	2	360	3	N	12	R
Series	Shaft type	Hollow type	Pulse/1Revolution	Output phase	Output	Power supply	Cable
Diameter ø20mm, S: Shaft type HB: Hollow shaft built-in type	External 2: ø2mm	Inner 2: ø2mm 2.5: ø2.5mm 3: ø3mm	100, 200, 320, 360	3: A, B, Z 6: A, \bar{A} , B, \bar{B} , Z, \bar{Z}	N: NPN open collector output V: Voltage output L: Line driver output(※)	5 : 5VDC ±5% 12: 12VDC ±5%	R: Axial cable type S: Radial cable type

※Standard: E20S2-[PULSE]-3-N-12-R
E20HB2-[PULSE]-3-N-12-R

※Standard: A, B, Z ※The power of Line driver is only for 5VDC

■ Specifications

Item	Diameter ø20mm shaft/hollow shaft built-in type incremental rotary encoder		
Resolution(P/R)	100, 200, 320, 360 (Not indicated pulse and output type is customizable.)		
Electrical specification	Output phase	A, B, Z phase (Line driver output A, \bar{A} , B, \bar{B} , Z, \bar{Z} phase)	
	Phase difference of output	Phase difference between A and B : $\frac{T}{4} \pm \frac{T}{8}$ (T=1 cycle of A phase)	
	Control output	NPN open collector output	Load current : Max. 30mA, Residual voltage : Max. 0.4VDC
		Voltage output	Load current : Max. 10mA, Residual voltage : Max. 0.4VDC
		Line driver output	• Low - Load current : Max. 20mA, Residual voltage : Max. 0.5VDC • High - Load current : Max. -20mA, Output voltage : Min. 2.5VDC
	Response time (Rise/Fall)	NPN open collector output	Max. 1μs
		Voltage output	Max. 1μs
		Line driver output	Max. 0.5μs
	Max. Response frequency	100kHz	
	Power supply	• 5VDC ±5%(Ripple P-P : Max. 5%) • 12VDC ±5%(Ripple P-P : Max. 5%)	
Current consumption	Max. 60mA(disconnection of the load), Line driver output : Max. 50mA(disconnection of the load)		
Insulation resistance	Min. 100MΩ(at 500VDC megger between all terminals and case)		
Dielectric strength	500VAC 50/60Hz for 1 minute(Between all terminals and case)		
Connection	Cable type(Axial / Radial)		
Mechanical specification	Starting torque	Max. 5gf·cm(5×10^{-4} N·m)	
	Moment of inertia	Max. 0.5g·cm ² (5×10^{-8} kg·m ²)	
	Shaft loading	Radial : 200gf, Thrust : 200gf	
	Max. allowable revolution ^{※1}	6000rpm	
Vibration	1.5mm amplitude or 300m/s ² at frequency of 10 to 55Hz(for 1 min.) in each of X, Y, Z directions for 2 hours		
Shock	Approx. Max. 50G		
Environment	Ambient temperature	-10 to 70°C, storage : -20 to 80°C	
	Ambient humidity	35 to 85%RH, storage : 35 to 90%RH	
Protection	IP50(IEC standard)		
Cable	ø3, 5-wire(Line driver output : 8-wire), Length : 1m, Shield cable		
Accessory	ø2mm Coupling(Shaft type), Bracket(Hollow shaft built-in type)		
Approval	CE (Except line driver output)		
Unit weight	Approx. 35g		

※1: Make sure that. Max response revolution should be lower than or equal to max. allowable revolution when selecting the resolution.

$$[\text{Max. response revolution}(\text{rpm})] = \frac{\text{Max. response frequency}}{\text{Resolution}} \times 60 \text{ sec}$$

※Environment resistance is rated at no freezing or condensation.

Incremental ø20mm Shaft/Hollow shaft built-in type

Control output diagram

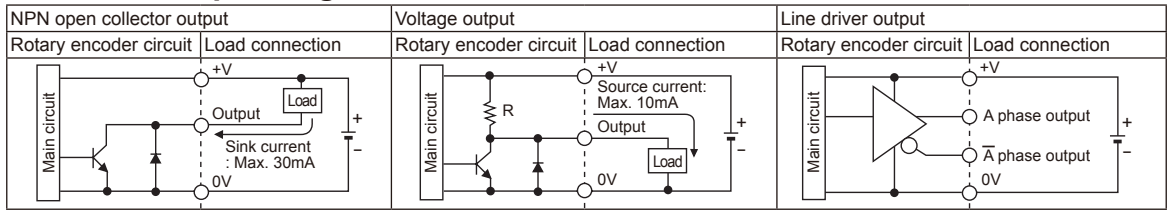

• The output circuit of A, B, Z phase are the same. (Line driver output is A, \bar{A} , B, \bar{B} , Z, \bar{Z})

Output waveform

NPN open collector output / Voltage output

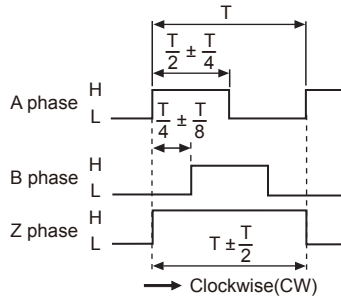

※ CW : Right turn as from the shaft

Line driver output

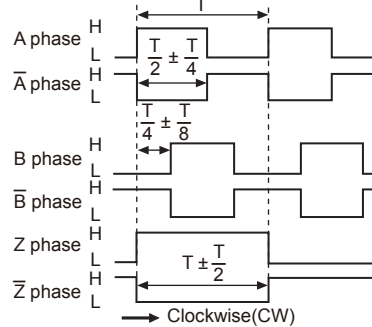

Connections

NPN open collector output / Voltage output

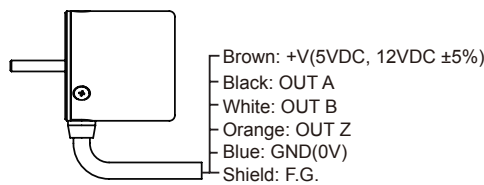

Line driver output

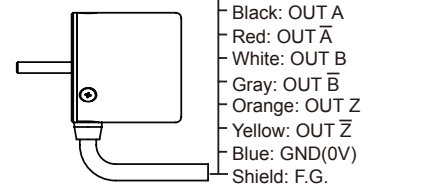

Dimensions

(unit: mm)

⊙ Axial cable type

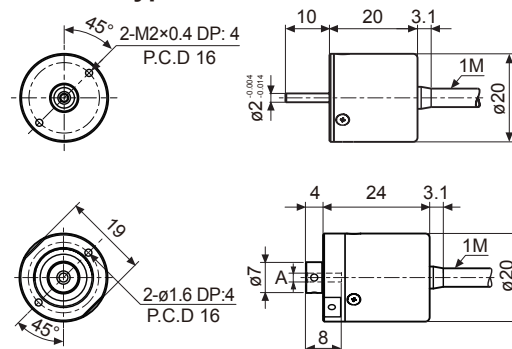

A	ø2	ø2.5	ø3
Tolerance	+0.014	+0.004	

⊙ Radial cable type

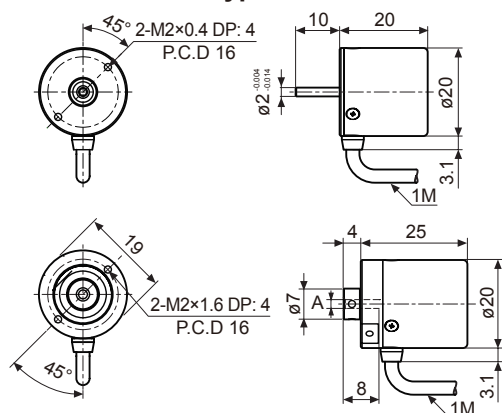

• Bracket(E20HB)

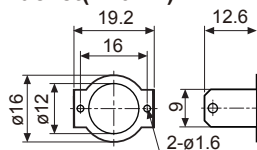

• Coupling(E20S)

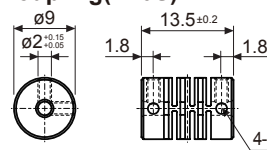

- Parallel misalignment: Max. 0.15mm
- Angular misalignment: Max. 2°
- End-play: Max. 0.2mm

※ For parallel misalignment, angular misalignment, end-play terms, refer to the F-78 page.

(A) Photo electric sensor

(B) Fiber optic sensor

(C) Door/Area sensor

(D) Proximity sensor

(E) Pressure sensor

(F) Rotary encoder

(G) Connector/Socket

(H) Temp. controller

(I) SSR/Power controller

(J) Counter

(K) Timer

(L) Panel meter

(M) Tacho/Speed/Pulse meter

(N) Display unit

(O) Sensor controller

(P) Switching mode power supply

(Q) Stepper motor& Driver&Controller

(R) Graphic/Logic panel

(S) Field network device

(T) Software

(U) Other